

PRIMARY SIDE REGULATOR WITH BUILT-IN HIGH VOLTAGE MOSFET

DESCRIPTION

SD6954 is primary side regulator (PSR) with built-in high voltage MOSFET. It adopts PFM technology and provides accurate constant voltage, constant current (CV/CC) control loop for high average efficiency and reliability.

Using SD6954 for system design, few peripheral components are needed without requiring the Opto-coupler, secondary control circuit and the loop compensation circuit which reduced the system cost.

SD6954 is suitable for 8~12W output power application with built-in cable drop compensation and peak current compensation.

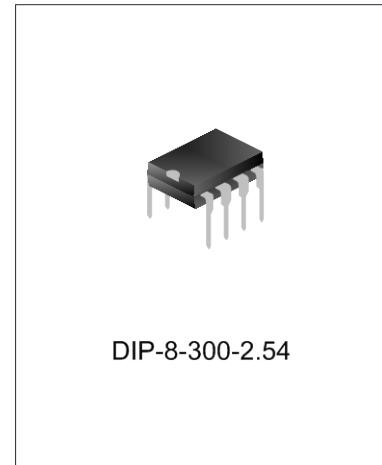

FEATURES

- ◆ Built-in high voltage MOSFET
- ◆ Primary side control
- ◆ Low start-up current
- ◆ Leading edge blanking
- ◆ Cycle by cycle current limiting
- ◆ Pulse-Frequency Modulation
- ◆ Peak reducing mode
- ◆ Overvoltage protection
- ◆ Undervoltage lockout
- ◆ Open Loop Protection
- ◆ Max. on time protection
- ◆ Over temperature protection
- ◆ Cable drop compensation
- ◆ Peak current compensation

APPLICATIONS

- ◆ Chargers
- ◆ Adapters
- ◆ Standby Power Supply

ORDERING INFORMATION

Part No.	Cable drop compensation	Package	Marking	Material	Packing
SD6954	6%	DIP-8-300-2.54	SD6954	Halogen free	Tube

BLOCK DIAGRAM

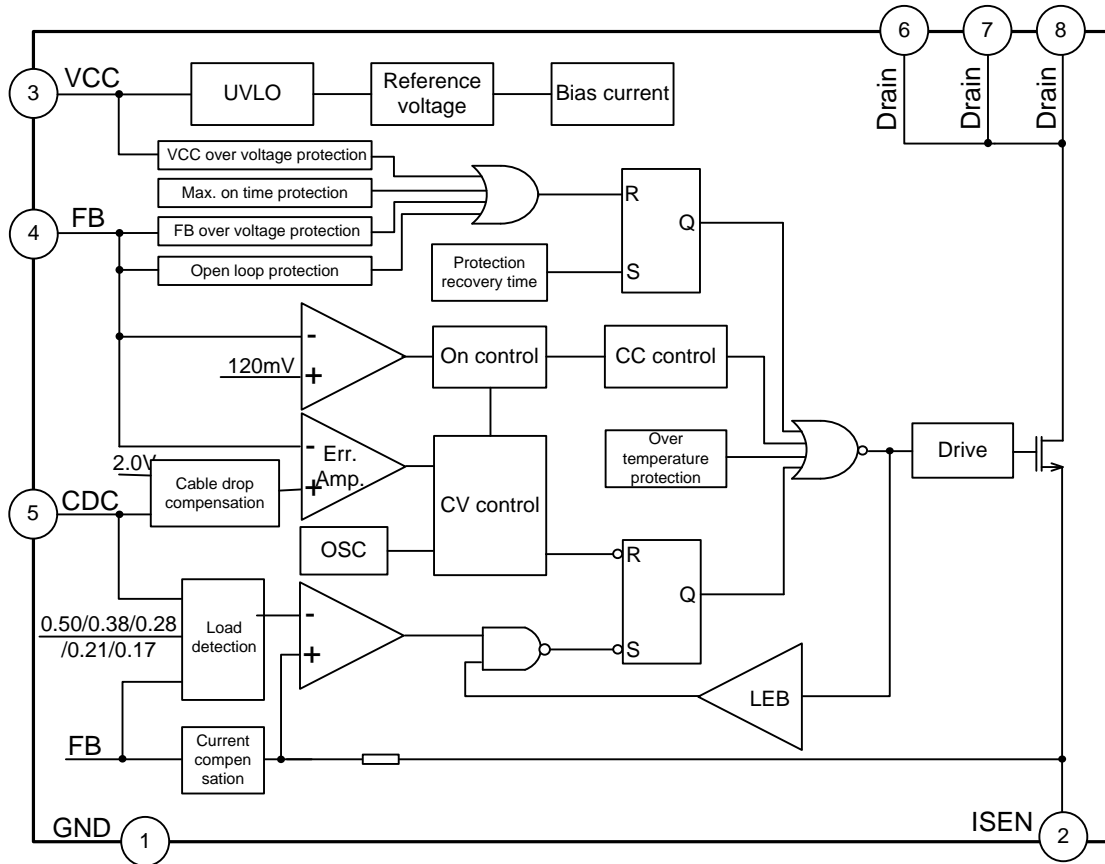

PIN CONFIGURATION

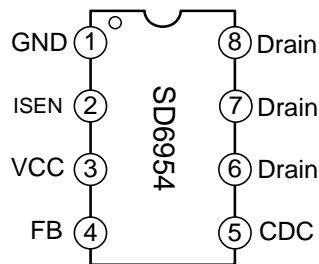

PIN DESCRIPTION

Pin No.	Pin Name	I/O	Function description
1	GND	G	Ground
2	ISEN	I	Peak current sense
3	VCC	P	Power supply
4	FB	I	Feedback voltage
5	CDC	I	Cable drop compensation
6, 7, 8	Drain	O	Drain of high voltage MOSFET

ABSOLUTE MAXIMUM RATING(unless otherwise specified, T_{amb}=25°C)

Characteristics	Symbol	Ratings	Unit
Supply Voltage	V _{CC}	-0.3~27	V
Internal Reference Voltage	V _{REF5V}	-0.3~5.5	V
FB Input Voltage	V _{FB}	-30~30	V
Other Input Voltage	V _{IN}	-0.3~ 5.5	V
Input Current	I _{IN}	-10~10	mA
Operating Junction Temperature	T _J	+150	°C
Ambient Temperature Range	T _{amb}	-20~ +85	°C
Storage Temperature Range	T _{STG}	-40~+150	°C
ESD (HBM)	ESD	2500	V
Drain-Source breakdown voltage	BV _{DSS}	650	V
Gate-Source voltage	V _{GS}	±30	V
Drain current	I _D	2.5	A
Drain pulse current	I _{DM}	10	A
Power dissipation	P _D	25	W
Single pulsed avalanche energy	E _{AS}	135	mJ

THERMAL CHARACTERISTICS

Characteristics	Symbol	Test conditions	Rating	Unit
Thermal Resistance, Junction-to-Case	R _{θJC}		5	°C/W
Thermal Resistance, Junction-to-Ambient	R _{θJA}		120	°C/W

ELECTRICAL CHARACTERISTICS OF MOSFET(unless otherwise specified, T_{amb}=25°C)

Characteristics	Symbol	Test conditions	Min.	Typ.	Max.	Unit
MOSFET current	I _D		--	--	2.5	A
Static Drain-Source On Resistance	R _{DS(ON)}	V _{GS} =10V, I _D =1.25A	--	3.8	4.8	Ω
Input Capacitance	C _{iss}	V _{GS} =0V, V _{DS} =25V, f=1MHz	220	320	420	pF
Output Capacitance	C _{oss}		28	40	52	
Reverse Transfer Capacitance	C _{rss}		0.85	1.25	1.65	
Turn On Delay Time	t _{d(ON)}	V _{DS} =0.5B _V DSS, V _{GS} =10V, I _D =2.5A	7	10	13	nS
Rise Time	t _r		20	28	36	
Turn Off Delay Time	t _{d(OFF)}		10	14	18	
Fall Time	t _f		12	18	24	
Drain-Source breakdown voltage	BV _{DSS}	V _{GS} =0V, I _D =50μA	650	--	770	V

ELECTRICAL CHARACTERISTICS (unless otherwise specified, $V_{CC}=18V$, $T_{amb}=25^{\circ}C$)

Characteristics	Symbol	Test conditions	Min.	Typ.	Max.	Unit
Supply Voltage						
Start-up Current	I_{ST}	$V_{CC}=16V$;	--	1.5	3	μA
Static Operating Current	I_{DD}	$I_{SEN}=0, FB=0$;	240	300	360	μA
Start Voltage	V_{ST}		16.3	17.8	19.3	V
Stop Voltage	V_{SP}		8.1	8.8	9.5	V
Internal Power Supply	V_{REF5V}		4.75	5.0	5.25	V
VCC Over Voltage Protection Voltage	V_{CCOVP}		25.5	27.0	28.7	V
Feedback						
Enable Voltage	V_{EN}		40	120	200	mV
Open Protection Voltage	V_{BLANK}		-0.8	-1.1	-1.4	V
Open Protection Delay Time	T_{BLANK}		0.8	1.2	1.6	μS
Constant Voltage Threshold	V_{CV}		3.96	4.00	4.04	V
FB Over Voltage Protection Voltage	V_{FBOVP}		6.2	6.9	7.6	V
Constant Voltage Off Time Limit	T_{OFFmax}		0.80	0.90	1.00	mS
	T_{OFFmin}		0.6	0.8	1.0	μS
Dynamic Parameter						
Leading-edge Blanking Time	T_{LEB}		0.35	0.45	0.55	μS
CV Loop Max. Duty Cycle ⁽¹⁾	D_{Smax}		49	50	51	%
Protection Recovery Time	T_{PRT}		13	14.5	16	mS
Max. On Time Protection	T_{ONmax}	$I_{SEN}=0V, FB=-2V$;	25	35	45	μS
Current Limit						
Peak Current Detecting Threshold 1	V_{PK1}	$1.00 < CDC < 2.00V$;	485	500	515	mV
Peak Current Detecting Threshold 2	V_{PK2}	$0.65 < CDC < 1.45V$;	368	380	392	mV
Peak Current Detecting Threshold 3	V_{PK3}	$0.40 < CDC < 1.05V$;	270	280	290	mV
Peak Current Detecting Threshold 4	V_{PK4}	$0.30 < CDC < 0.75V$;	204	210	216	mV
Peak Current Detecting Threshold 5	V_{PK5}	$0 < CDC < 0.60V$;	165	170	175	mV
Compensation						
Cable Drop Compensation	$\Delta FB/FB$		--	6	--	%
Peak Current Compensation	ΔV_{PK}	$CDC=5V, FB=-10V$	40	50	60	mV
OTP						
Over Temperature Protection	T_{OTP}		140	145	150	$^{\circ}C$
Over Temperature Hysteresis	T_{OTP_hys}		--	30	--	$^{\circ}C$

Note1: CV Loop Duty Cycle, the ratio is secondary on time in the whole period, is defined as D_s , $D_{smax}=0.5$.

TYPICAL CHARACTERISTICS

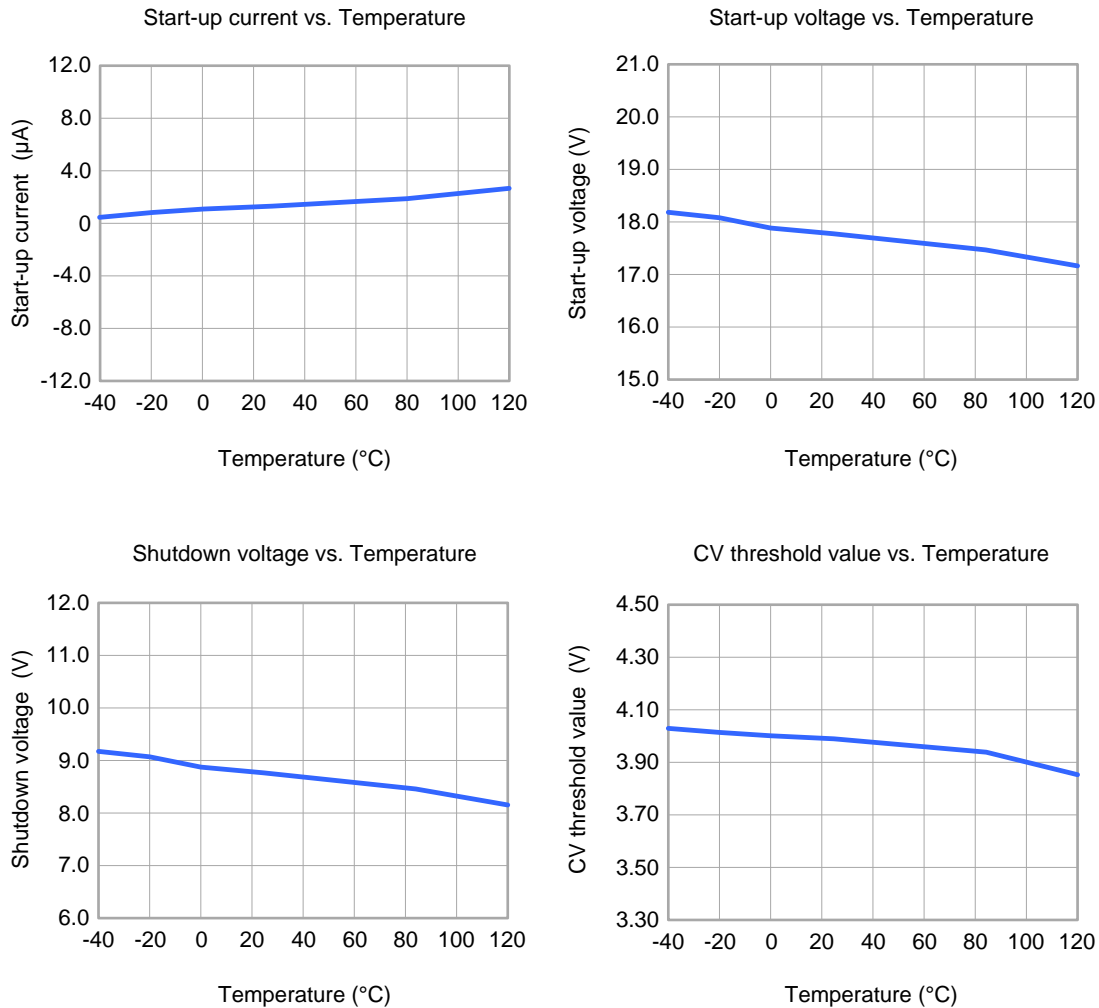

FUNCTION DESCRIPTION

SD6954 is controller designed for off-line SMPS. It features built-in cable drop compensation and peak current compensation. CV/CC output is obtained through output voltage/current controlled by detecting feedback voltage of auxiliary winding and peak current of primary winding.

The whole operating period consists of peak current detection and feedback voltage detection.

When MOSFET is on, primary current is detected by sense resistor and voltage at pin FB is negative, load is powered by output capacitor and output voltage V_O decreases. When primary current exceeds the limit, MOSFET is off and voltage at pin FB is detected. Output capacitor and load are powered by secondary current and V_O increases. MOSFET is on again after the CV/CC control open conditions are satisfied at the same time. And then, it comes to peak current detecting again.

1. Start-up and under voltage lockout

After power on, the capacitor connected to pin V_{CC} is charged by high voltage DC bus via start resistor and the circuit starts to work if voltage at V_{CC} is 17.8V. The circuit is powered by start resistor and auxiliary winding during normal operation. The whole control circuit enters undervoltage lockout if V_{CC} is decreased to 8.8V, capacitor connected to pin

V_{CC} is charged through start resistor and IC only restarts when $V_{CC}=17.8V$.

2. Peak current detection

When driving voltage is high, MOSFET is on, the linearly increased primary current is detected by the sense resistor. When this current increases to the threshold value (peak value), the MOSFET is off.

There is a burr when MOSFET is on, and MOSFET will be off by error if its voltage is up to the threshold value V_{PK} for the peak current. So the leading edge blanking time $T_{LEB}=0.45\mu s$ is set to avoid this error.

Detect the system load according to the voltage on pin CDC. Following the system load increasing,

- 0<CDC<0.60V, peak current threshold $V_{PK5}=170mV$;
- 0.30<CDC<0.75V, peak current threshold $V_{PK4}=210mV$;
- 0.40<CDC<1.05V, peak current threshold $V_{PK3}=280mV$;
- 0.65<CDC<1.45V, peak current threshold $V_{PK2}=380mV$;
- 1.00<CDC<2.00V, peak current threshold $V_{PK1}=500mV$;

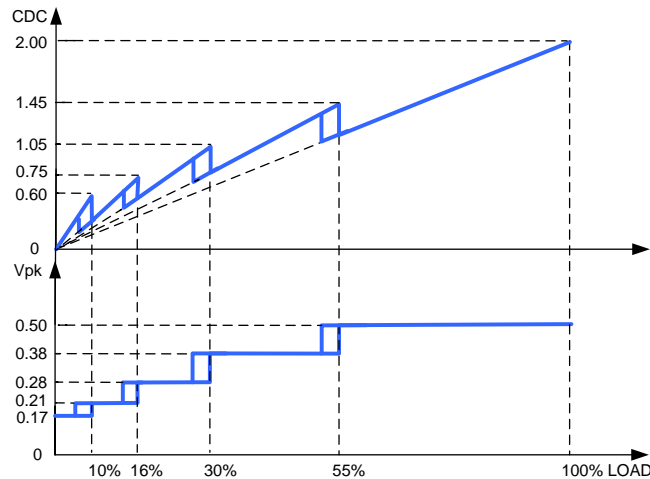

3. Peak current compensation

The detected peak current value will increase following the input AC voltage due to the off delay. And the output current is deeply affected by the peak current, hence the voltage regulation is worse without peak current compensation.

SD6954 uses the negative feedback voltage on pin FB to detect AC input voltage and then generates a CC source, which is superposed on the peak current sense pin ISEN to make the peak current constant under different input voltages, which will improve the regulation rate of output current.

4. Feedback Voltage Detection

When MOSFET is off, the voltage at pin FB is positive and voltage is sensed at 2/3 duration of this positive voltage, this sensed voltage is used to generate off time T_{OFF} of CV loop circuit after compared with V_{CV} , amplified and held. Then CV output is available.

T_{OFF1} , T_{OFF2} and T_{ON} are counted at the same time which indicates durations of positive FB voltage, FB damping oscillation and FB negative voltage respectively. Positive FB voltage indicates there is current delivered to the secondary side of transformer, while negative and FB damping oscillation indicate there is no current delivered to the secondary side of transformer.

The duty factor is expressed as:

$$D_S = \frac{T_{OFF1}}{T_{OFF1} + T_{OFF2} + T_{ON}} = \frac{T_{OFF1}}{T};$$

Output current, also the average current in secondary winding:

$$I_{OUT} = \frac{I_{SP} \cdot T_{OFF1}}{2T} = \frac{nD_S}{2} I_{PK};$$

I_{SP} —peak current in secondary winding, I_{PK} —peak current in primary winding, n —turns ratio of primary/secondary windings.

Hence, with constant peak current, when $D_S = D_{Smax} = 0.50$ (this value is determined by internal circuit), the circuit enters constant-current mode and output current is kept constant.

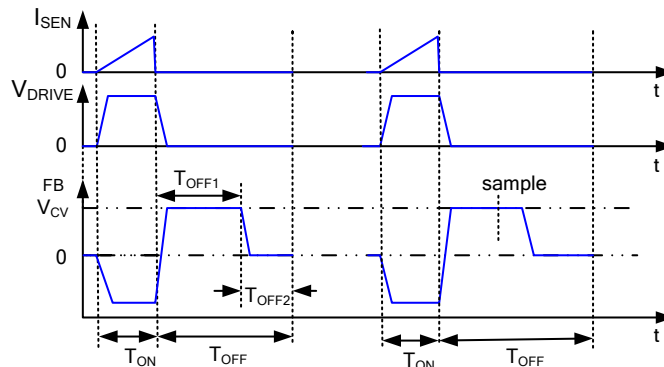

5. Cable drop compensation

In the actual design, the cable voltage drop V_{CAB} should be taken into consideration:

V_D is almost constant with different currents, so we focus on the cable voltage drop V_{CAB} that is proportional to output current, which is needed to be compensated to get better voltage regulation.

According to the output current calculation formula, under the condition that the peak current is constant, the duty cycle D_S can stand for the load of output current:

The duty cycle is almost 0 before compensation and the CV threshold value is 4.0V; the duty cycle with full load is 0.5 after compensation and the CV threshold value is 4.24V. The cable drop compensation efficient is 6% for SD6954.

6. Over voltage protection for FB

The output is shutdown if voltage at FB exceeds the threshold $V_{FBOVP} = 6.9V$ and this state is kept for 14.5ms, then the driver restarts.

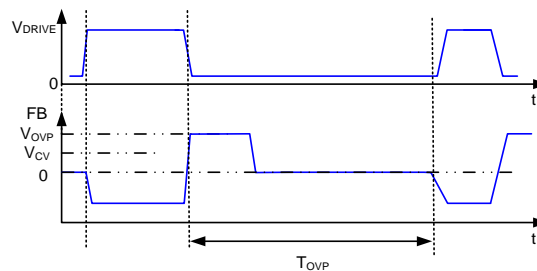

7. Open loop protection

When power MOS is on, if FB negative voltage is higher than -1.1V, the loop is open; and the open-loop protection acts if there is no change after 1.2μs delay; the drive is shutdown and restart after 14.5ms.

8. Max. on time protection

When pin ISEN is floating, the peak current can't be detected, while system maybe damaged by actual abnormal peak current. Max. on time is needed. When $T_{ONmax}=35\mu s$, it enters max. on time protection and the drive is shutdown, it restarts after keeping this for 14.5ms.

9. VCC over voltage protection

VCC is active when VCC voltage is higher than 27.0V, th drive is shutdown and it restarts after keeping for 14.5ms.

10. Over Temperature Protection

If the circuit is over temperature, the output is shut down to prevent the circuit from damage. The hysteresis of over temperature protection is used to avoid frequently change between normal and protection modes. The over protection threshold value is 145°C and hysteresis value is about 30°C. Hence, the circuit is only normal when the temperature is 115°C below.

11. PFM frequency setting

PFM frequency range is determined by the on time T_{ON} and constant-voltage loop off time T_{OFF} . When off time is T_{OFFmax} , the circuit works with operating frequency value is minimum; when off time is T_{OFFmin} , the circuit works with perating frequency value is maximum.

$$\text{According to the formula: } P_o = V_o \cdot I_o = \frac{1}{2} L_m I_{PK}^2 \cdot f_s \cdot \eta$$

Where, L_m —primary inductance, I_{PK} —peak current in primary side, f_s —operating frequency, η —efficiency.

$$\text{Hence, } f_s = \frac{2V_o \cdot I_o}{L_m I_{PK}^2 \cdot \eta}$$

TYPICAL APPLICATION CIRCUIT

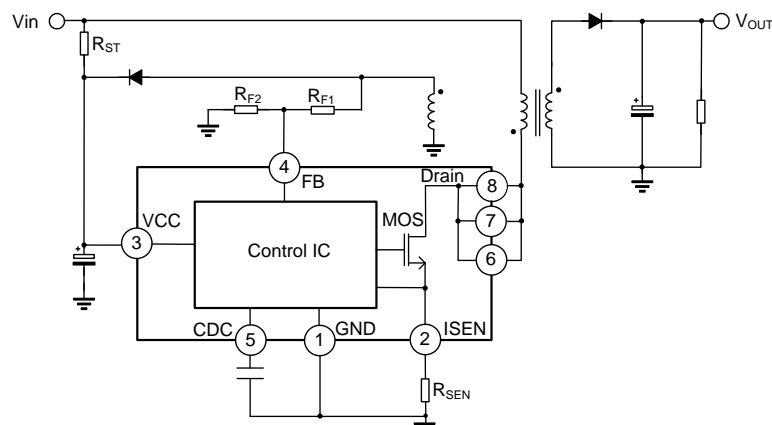

Note: The circuit and parameters are for reference only; please set the parameters of the real application circuit based on the real test.

PACKAGE OUTLINE

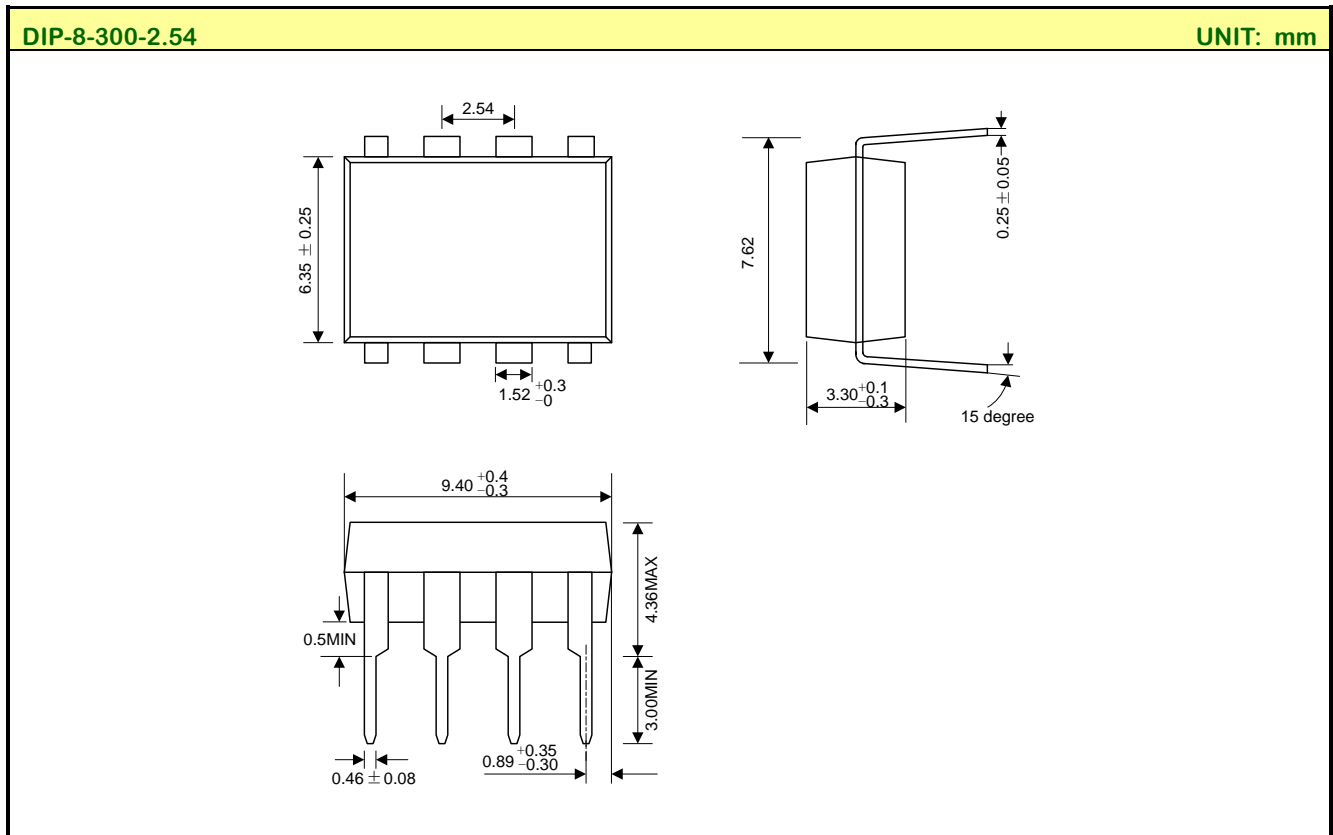

MOS DEVICES OPERATE NOTES:

Electrostatic charges may exist in many things. Please take following preventive measures to prevent effectively the MOS electric circuit as a result of the damage which is caused by discharge:

- The operator must put on wrist strap which should be earthed to against electrostatic.
- Equipment cases should be earthed.
- All tools used during assembly, including soldering tools and solder baths, must be earthed.
- MOS devices should be packed in antistatic/conductive containers for transportation.

Disclaimer :

- Silan reserves the right to make changes to the information herein for the improvement of the design and performance without further notice! Customers should obtain the latest relevant information before placing orders and should verify that such information is complete and current.
- All semiconductor products malfunction or fail with some probability under special conditions. When using Silan products in system design or complete machine manufacturing, it is the responsibility of the buyer to comply with the safety standards strictly and take essential measures to avoid situations in which a malfunction or failure of such Silan products could cause loss of body injury or damage to property.
- Silan will supply the best possible product for customers!

Part No.:	SD6954	Document Type:	Datasheet
Copyright:	HANGZHOU SILAN MICROELECTRONICS CO.,LTD	Website:	http://www.silan.com.cn

Rev.:	1.1	Author:	Jiang Xuming
-------	-----	---------	--------------

Revision History:

1. Modify the constant voltage threshold
-

Rev.:	1.0	Author:	Jiang Xuming
-------	-----	---------	--------------

Revision History:

1. First release
-